

limited to, loss of use, loss of profits, loss of production, expense of substitute equipment or other commercial loss or damage.

Limitation of Liability: This limited warranty is in lieu of all other express warranties, obligations, or liabilities. Any implied warranties, obligations or liabilities, including, but not limited to, any implied warranty of merchantability shall be limited in duration to the applicable warranty period. Any action for breach of any warranties hereunder, including, but not limited to, any implied warranty of merchantability must be brought within the applicable warranty period.

Modifications of Warranty: No agent, representative, dealer, or employee of KisanKraft Limited or any of its manufacturers has the authority to increase or alter the obligations of this warranty.

Assignment / Transfer of warranty: The warranty cannot be assigned and shall not transfer if the product is resold by the first buyer. The above warranties are extended to the first end user (original purchaser), and no warranty is made, nor authorized to be made assignable on resale by the first end user.

What you must do to obtain limited warranty service: To obtain performance of any obligation under this warranty for failure during the applicable warranty period, you must deliver the defective product, to the nearest Authorized Dealer, along with proof-of-purchase (invoice/receipt). KisanKraft Limited, its manufacturers and its dealers reserve the right to inspect the claimed defective part(s) to determine if the malfunction is the result of a defect covered by this warranty. Please note that the decision of KisanKraft Limited with respect to any warranty claim is final.

After-sales Service (Including Warranty): KisanKraft Limited does not sell directly to consumers. All sales or supplies are made through Authorized Dealers. It is the responsibility of the Authorized Dealer to provide all after-sales service to consumers. Any warranty claim should be raised by dealer to KisanKraft Limited as per warranty policy.

Jurisdiction: All disputes are subject to Bangalore court's jurisdiction.

Notes:

- This purchase is not contingent upon a product demonstration. The purchaser shall satisfy himself with the product, including any product demonstration or verification of any function, before buying. KisanKraft Limited or its authorized dealers, including online sellers, shall not be liable to give any on-site demonstration after purchase of any of the product.
- Any product once used will not be taken back by KisanKraft Limited.
- Warranty and After Sale Services (including but not limited to installation, Demonstration, Repair, Routine Maintenance etc.), should be done through the Authorized Dealer selling this product.
- Dealers should have their own technician to provide After Sales Services to their Customers. KisanKraft Limited provides free training to Authorized Dealer's technicians at KisanKraft Limited's head office, on request from Authorized Dealer.

This warranty is null & void, if you fail to register the warranty with KisanKraft by sending the KisanKraft Copy with dealer's stamp.

Product	Agricultural Knapsack Sprayer (Power)	KisanKraft Invoice Date	
Brand	KisanKraft	KisanKraft Invoice No.	
Model	<input type="checkbox"/> KK-KPS-204B <input type="checkbox"/> KK-KPS-222B		
WARRANTY PERIOD	6-MONTHS	FOR THE SPECIFIED PERIOD FROM THE DATE OF SALE OR DELIVERY WHICHEVER IS EARLIER.	
Dealer's Invoice Date		Dealer's Invoice No.	
Buyer's Info (Name, Address, Phone, etc.):		Dealer's Stamp (Address, Phone, TIN, etc.):	
Buyer's Sign		Dealer's Sign	

Warranty Policy

What is covered: KisanKraft Limited and its manufacturers warrant this product to be free from defects in material or workmanship. All parts defective in material and workmanship are covered.

This warranty will only cover defects arising under normal usage.

This warranty is limited to repair or replacement by KisanKraft Limited or its manufacturers of such parts as appear to KisanKraft or its manufacturers, upon inspection, to be defective in material and/or workmanship. KisanKraft or its manufacturers make no warranty with respect to items not manufactured or sold by them. No onsite warranty is provided by KisanKraft Limited or its manufacturers. Defective items must be brought/sent to our Authorized Dealer or KisanKraft Limited's office for service.

What is not covered: The warranty shall become null and void and neither KisanKraft Limited nor any of its manufacturers, nor its authorized dealers assume any responsibility, if the failure was caused by the following:

- (1) Operation of product with incorrect fuel or lubricants,
- (2) Incorrect usage of machine or misuse,
- (3) Lack of maintenance,
- (4) Negligence,
- (5) Accident or physical damage,
- (6) Repairs made by unauthorized parties and/or with unauthorized parts,
- (7) Improper set up, adjustments, tampering or altered products
- (8) Any modification to the product what-so-ever.

Important: (1) Normal maintenance and adjustments to the product is the responsibility of the customer. (2) Normal wear and tear are not covered under warranty. (3) Rubber/plastic parts and consumables such as blades, clutch and clutch-bell, sparkplugs, nylon line, air-filters, fuel-filters, oil seals and gaskets etc. are not covered under the warranty. (4) Electrical Motor, Electrical Parts, Battery Etc. are not covered under the warranty.

Incidental / Consequential Loss: KisanKraft Limited or its manufacturers will not be liable for general damages, including bodily injuries, or for incidental or consequential damages including, but not limited to, loss of use, loss of profits, loss of production, expense of substitute equipment or other commercial loss or damage.

Limitation of Liability: This limited warranty is in lieu of all other express warranties, obligations, or liabilities. Any implied warranties, obligations, or liabilities, including, but not limited to, any implied warranty of merchantability shall be limited in duration to the applicable warranty period. Any action for breach of any warranties hereunder, including, but not limited to, any implied warranty of merchantability must be brought within the applicable warranty period.

Modifications of Warranty: No agent, representative, dealer, or employee of KisanKraft Limited or any of its manufacturers has the authority to increase or alter the obligations of this warranty.

Assignment / Transfer of warranty: The warranty cannot be assigned and shall not transfer if the product is resold by the first buyer. The above warranties are extended to the first end user (original purchaser), and no warranty is made, nor authorized to be made assignable on resale by the first end user.

What you must do to obtain limited warranty service: To obtain performance of any obligation under this warranty for failure during the applicable warranty period, you must deliver the defective product, to the nearest Authorized Dealer, along with proof-of-purchase (invoice/receipt). KisanKraft Limited, its manufacturers and its dealers reserve the right to inspect the claimed defective part(s) to determine if the malfunction is the result of a defect covered by this warranty. Please note that the decision of KisanKraft Limited with respect to any warranty claim is final.

After-sales Service (Including Warranty): KisanKraft Limited does not sell directly to consumers. All sales or supplies are made through Authorized Dealers. It is the responsibility of the Authorized Dealer to provide all after-sales service to consumers. Any warranty claim should be raised by dealer to KisanKraft Limited as per warranty policy.

Jurisdiction: All disputes are subject to Bangalore court's jurisdiction.

Notes:

- This purchase is not contingent upon a product demonstration. The purchaser shall satisfy himself with the product, including any product demonstration or verification of any function, before buying. KisanKraft Limited or its authorized dealers, including online sellers, shall not be liable to give any on-site demonstration after purchase of any of the product.
- Any product once used will not be taken back by KisanKraft Limited.
- Warranty and After Sale Services (including but not limited to installation, Demonstration, Repair, Routine Maintenance etc.), should be done through the Authorized Dealer selling this product.
- Dealers should have their own technician to provide After Sales Services to their Customers. KisanKraft Limited provides free training to Authorized Dealer's technicians at KisanKraft Limited's head office, on request from Authorized Dealer.

Product	Agricultural Knapsack Sprayer (Power)	KisanKraft Invoice Date	
Brand	KisanKraft	KisanKraft Invoice No.	
Model	<input type="checkbox"/> KK-KPS-204B, <input type="checkbox"/> KK-KPS-222B,		
WARRANTY PERIOD	6-Months	FOR THE SPECIFIED PERIOD FROM THE DATE OF SALE OR DELIVERY WHICHEVER IS EARLIER.	
Dealer's Invoice Date		Dealer's Invoice No.	
Buyer's Info (Name, Address, Phone, etc.):		Dealer's Stamp (Address, Phone, TIN, etc.):	
Buyer's Sign		Dealer's Sign	

Warranty Policy

What is covered: KisanKraft Limited and its manufacturers warrant this product to be free from defects in material or workmanship. All parts defective in material and workmanship are covered. This warranty will only cover defects arising under normal usage. This warranty is limited to repair or replacement by KisanKraft Limited or its manufacturers of such parts as appear to KisanKraft or its manufacturers, upon inspection, to be defective in material and/or workmanship. KisanKraft or its manufacturers make no warranty with respect to items not manufactured or sold by them. No onsite warranty is provided by KisanKraft Limited or its manufacturers. Defective items must be brought/sent to our Authorized Dealer or KisanKraft Limited's office for service.

What is not covered: The *warranty shall become null and void* and neither KisanKraft Limited nor any of its manufacturers, nor its authorized dealers assumes any responsibility, if the failure was caused by the following:

- (1) Operation of product with incorrect fuel or lubricants,
- (2) Incorrect usage of machine or misuse,
- (3) Lack of maintenance,
- (4) Negligence,
- (5) Accident or physical damage,
- (6) Repairs made by unauthorized parties and/or with unauthorized parts,
- (7) Improper set up, adjustments, tampering or altered products
- (8) Any modification to the product what-so-ever.

Important: (1) Normal maintenance and adjustments to the product is the responsibility of the customer. (2) Normal wear and tear are not covered under warranty. (3) Rubber/plastic parts and consumables such as blades, clutch and clutch-bell, sparkplugs, nylon line, air-filters, fuel-filters, oil seals and gaskets etc. are not covered under the warranty. (4) Electrical Motor, Electrical Parts, Battery Etc. are not covered under the warranty.

Incidental / Consequential Loss: KisanKraft Limited or its manufacturers will not be liable for general damages, including bodily injuries, or for incidental or consequential damages including, but not

This warranty is null & void, if you fail to register the warranty with KisanKraft by sending the KisanKraft Copy with dealer's stamp.



Wide Range of Products for Every Need



User Manual



KisanKraft Limited

Warehouse: 818 3B1 to 818 3B18, Podalukur - Sangam Road, Prabagiripatnam, Podalukur, Nellore - 524345, Andhra Pradesh, INDIA
Head Office: #4, 1st Main, 7-A Cross, Maruthi Layout, Dasarahalli, HAF Post, Hebbal, Bangalore 560024, Karnataka, INDIA

- ◆ Bangalore (HO) ◆ Ahmedabad ◆ Bhopal ◆ Bhubaneswar ◆ Coimbatore
- ◆ Guwahati ◆ Hubli ◆ Hyderabad ◆ Jaipur ◆ Karnal
- ◆ Kolkata ◆ Lucknow ◆ Nellore ◆ Pune ◆ Raipur



Scan the QR code to download KisanKraft App

App is available on Google Play



Scan the QR code for KisanKraft Youtube Channel

YouTube

For more information give **MISSED CALL: 07676065555**



Many of our products have BIS: ISI certification.



CONTENTS

BEFORE GETTING STARTED7

SAFETY INSTRUCTIONS.....7

OVERVIEW OF COMPONENTS.....8

ASSEMBLY9

OPERATING INSTRUCTIONS9

MAINTENANCE AND STORAGE 12

TECHNICAL SPECIFICATIONS 14

POWER SPRAYER- DIAGRAM-ENGINE..... 17

PRESSURE SPRAYER PARTS - DIAGRAM 18

PRESSURE PUMP PARTS-LIST 19

USER MANUAL-4 STROKE PETROL ENGINE..... 21

KisanKraft has a large range of products to serve the farmers. A list of our products is given below:

<p>Brush Cutters and Accessories</p> <ul style="list-style-type: none"> Brush Cutter/Power Weeder Backpack Brush Cutter Tea Pruner Pole pruner with Engine Reaper Attachment Blades-Circular Blades (2 &3 points) Baffle Nylon Rope Tap & Go <p>Chainsaws</p> <ul style="list-style-type: none"> Petrol Chainsaw Electric Chainsaw Chain Sharpening Machine <p>Engines and Water Pumps</p> <ul style="list-style-type: none"> Engine –Diesel-(Horizontal) Engine –Diesel(Vertical) Engine-Kerosene Water Pump with Petrol Engine Water Pump with Kerosene Engine Water Pump with Diesel Engine <p>Hand Tools</p> <ul style="list-style-type: none"> Secateurs Folding Saw Garden Rake Garden Shovel Hedge Shear Lopper Telescopic Hedge Shear Telescopic Lopping Shear Tree Pruner Telescopic Steel Pipe & Fruit Picker Bag Sheep Shear <p>Garden Tools</p> <ul style="list-style-type: none"> Electric Pressure Washer Hedge Trimmer Lawn Mower (Electric, Petrol & Manual) Leaf Blower 	<p>Cultivators and Accessories</p> <ul style="list-style-type: none"> Petrol and Diesel <p>Sprayers and Accessories</p> <ul style="list-style-type: none"> Battery Sprayer Portable Power Sprayer Trolley Sprayer Manual Knapsack Sprayer Manual Pressure Sprayer Rose Cans Hose Crimping Machine HTP Sprayer HTP Delivery Hose HTP Hose Reel HTP Stand HTP Gun / Lance(Brass Rod) Knapsack Power Sprayer Mister / Duster / Granule Sprayer HTP Sprayer Set with Diesel Engine HTP Sprayer Set with Kerosene Engine Fogging Machine <p>Milking Machine</p> <ul style="list-style-type: none"> Wood Shredder Fodder Ensiling Chaff Cutter Fodder Grinder Chaff Cutter Fodder Mini Chaff Cutter <p>Harvester</p> <ul style="list-style-type: none"> Maize Sheller Maize Sheller + Dehusker Maize Combine Harvester Onion Digger Carlotta Italy Tea Leaf Harvester Sugarcane Combine Harvester Sugarcane Leaf Stripper <p>Transplanter and Post Hole Digger</p> <ul style="list-style-type: none"> Paddy Transplanter (2 & 8 Rows) Transplanter-Vegetable & Tobacco Post Hole Digger(4” to 14”Augers)
---	---

TRANSPORTATION AND STORAGE

Handle with care during loading and unloading; laying upside down and inclined placing are strictly prohibited. The damage due to collision is strictly prohibited during transportation, and it is also required to prevent it from exposure to rain. If the engine is to be stored for a long time and will not be used,

- Place it at a clean, ventilated, dry and damp-proof place;
- Completely discharge the fuel in the engine (including the engine oil in the oil-bath type air filter);
- The effective oil seal period should not be less than 6 months under normal conditions of packaging, transport and storage.

INSTRUCTIONS FOR UNPACKING

- During unpacking, the fuel engine shall be in the upright state; always handle with care!
- After unpacking, firstly check for the Packing List, certificates, Warranty Card and Operation Manual. Carefully check and verify whether the real products are in compliance against the Packing List.
- The fuel engines provided by our company are of high-quality, environment-friendly and of high performance-price ratio. In case of any trouble encountered or any question during your operation, please contact the dealer.

Product	Agricultural Knapsack Sprayer (Power)	KisanKraft Invoice Date	
Brand	KisanKraft	KisanKraft Invoice No.	
Model	<input type="checkbox"/> KK-KPS-204B <input type="checkbox"/> KK-KPS-222B		
WARRANTY PERIOD	6-MONTHS	FOR THE SPECIFIED PERIOD FROM THE DATE OF SALE OR DELIVERY WHICHEVER IS EARLIER.	
Dealer's Invoice Date		Dealer's Invoice No.	
Buyer's Info (Name, Address, Phone, etc.):		Dealer's Stamp (Address, Phone, TIN, etc.):	
Buyer's Sign		Dealer's Sign	

Warranty Policy

What is covered: KisanKraft Limited and its manufacturers warrant this product to be free from defects in material or workmanship. All parts defective in material and workmanship are covered.

This warranty will only cover defects arising under normal usage.

This warranty is limited to repair or replacement by KisanKraft Limited or its manufacturers of such parts as appear to KisanKraft or its manufacturers, upon inspection, to be defective in material and/or workmanship. KisanKraft or its manufacturers make no warranty with respect to items not manufactured or sold by them. No onsite warranty is provided by KisanKraft Limited or its manufacturers. Defective items must be brought/sent to our Authorized Dealer or KisanKraft Limited's office for service.

What is not covered: The warranty shall become null and void and neither KisanKraft Limited nor any of its manufacturers, nor its authorized dealers assume any responsibility, if the failure was caused by the following:

- Operation of product with incorrect fuel or lubricants,
- Incorrect usage of machine or misuse,
- Lack of maintenance,
- Negligence,
- Accident or physical damage,
- Repairs made by unauthorized parties and/or with unauthorized parts,
- Improper set up, adjustments, tampering or altered products
- Any modification to the product what-so-ever.

Important: (1) Normal maintenance and adjustments to the product is the responsibility of the customer. (2) Normal wear and tear are not covered under warranty. (3) Rubber/plastic parts and consumables such as blades, clutch and clutch-bell, sparkplugs, nylon line, air-filters, fuel-filters, oil seals and gaskets etc. are not covered under the warranty. (4) Electrical Motor, Electrical Parts, Battery Etc. are not covered under the warranty.

This warranty is null & void, if you fail to register the warranty with KisanKraft by sending the KisanKraft Copy with dealer's stamp.

Incidental / Consequential Loss: KisanKraft Limited or its manufacturers will not be liable for general damages, including bodily injuries, or for incidental or consequential damages including, but not limited to, loss of use, loss of profits, loss of production, expense of substitute equipment or other commercial loss or damage.

Limitation of Liability: This limited warranty is in lieu of all other express warranties, obligations, or liabilities. Any implied warranties, obligations, or liabilities, including, but not limited to, any implied warranty of merchantability shall be limited in duration to the applicable warranty period. Any action for breach of any warranties hereunder, including, but not limited to, any implied warranty of merchantability must be brought within the applicable warranty period.

Modifications of Warranty: No agent, representative, dealer, or employee of KisanKraft Limited or any of its manufacturers has the authority to increase or alter the obligations of this warranty.

Assignment / Transfer of warranty: The warranty cannot be assigned and shall not transfer if the product is resold by the first buyer. The above warranties are extended to the first end user (original purchaser), and no warranty is made, nor authorized to be made assignable on resale by the first end user.

What you must do to obtain limited warranty service: To obtain performance of any obligation under this warranty for failure during the applicable warranty period, you must deliver the defective product, to the nearest Authorized Dealer, along with proof-of-purchase (invoice/receipt). KisanKraft Limited, its manufacturers and its dealers reserve the right to inspect the claimed defective part(s) to determine if the malfunction is the result of a defect covered by this warranty. Please note that the decision of KisanKraft Limited with respect to any warranty claim is final.

After-sales Service (Including Warranty): KisanKraft Limited does not sell directly to consumers. All sales or supplies are made through Authorized Dealers. It is the responsibility of the Authorized Dealer to provide all after-sales service to consumers. Any warranty claim should be raised by dealer to KisanKraft Limited as per warranty policy.

Jurisdiction: All disputes are subject to Bangalore court’s jurisdiction.

Notes:

- This purchase is not contingent upon a product demonstration. The purchaser shall satisfy himself with the product, including any product demonstration or verification of any function, before buying. KisanKraft Limited or its authorized dealers, including online sellers, shall not be liable to give any on-site demonstration after purchase of any of the product.
- Any product once used will not be taken back by KisanKraft Limited.
- Warranty and After Sale Services (including but not limited to installation, Demonstration, Repair, Routine Maintenance etc.), should be done through the Authorized Dealer selling this product.
- Dealers should have their own technician to provide After Sales Services to their Customers. KisanKraft Limited provides free training to Authorized Dealer’s technicians at KisanKraft Limited’s head office, on request from Authorized Dealer

This warranty is null & void, if you fail to register the warranty with KisanKraft by sending the KisanKraft Copy with dealer’s stamp.

Abnormal Situations during Operation:

Situations	Causes	Remedy
Rotating speed cannot be increased; insufficient power	Throttle is close.	Open the throttle.
	The ventilation of the muffler is not smooth	Replace the muffler.
	Moving members are worn	Inspect and replace them.
	The ignition energy is low.	Replace the igniter or the flywheel.
	The valve clearance is excessive	Adjust or replace relevant parts.
Spitting during operation	Carbon is deposited on the cylinder head.	Remove the deposited carbon.
	Blocked oil path of the carburetor	Replace the carburetor.
Abnormal sound	Excessive or insufficient clearance of the spark plug	Adjust the clearance
	Incorrect clearance of the throttle	Replace relevant parts.
Oil leakage of carburetor	Damaged cam teeth	Replace the cam shaft
	Failure of the non-return valve on fuel tank cap	Replace the non-return vent valve of the fuel tank cap.
	Damaged sealing elements of carburetor	Replace them.

Contact the dealer if the fuel engine still has problems after inspection and repair based on the methods above.

TROUBLESHOOTING

Startup Failure or Difficulty in Startup

Situations		Causes	Remedy	
The spark plug is fireless.	Spark plug	Carbon deposition on the spark plug.	Remove the deposited carbon.	
		Excessive or insufficient clearance of the spark plug.	Adjust it to 0.6~0.7mm.	
		Damaged insulation of the spark plug	Replace the spark plug.	
	Others	Damaged igniter	Replace the igniter.	
		Weak magnetic force of the flywheel	Replace the flywheel.	
The spark plug cannot generate spark.	Good compression	Too much fuel adsorbed in the cylinder	Screw out the spark plug, dry it and screw it in again.	
		Poor fuel, containing water, too dirty	Replace the fuel	
	The carburetor oil pump has (not) the ability to pump oil.	Blocked internal oil path		Clean or replace the carburetor.
		Normal oil supply but poor compression	Worn piston ring	Replace the piston ring
	Loose spark plug		Tighten the spark plug.	
	Air leakage at the cylinder head, incorrect valve clearance or timing		Removal, re-adjustment or re-installation	
	Normal ignition and oil supply	Poor contact between the high-tension line and the spark plug	Remove and reconnect the line properly	
		Malfunction or short-circuit of shutdown switch	Replace the shutdown switch	

BEFORE GETTING STARTED

Please read and follow the instructions in this manual before using the machine. The user should be familiar with the safety notices, machine performance, and maintenance, etc. The operation manual will be used later in case of any repair, accessories replacement, and accessories procurement, so preserve it carefully.

SAFETY INSTRUCTIONS

- Using this machine with extra high pressure is prohibited ($\leq 35\text{kgf/cm}^2$).
- The rotating parts should have a safety protective device.
- Protective Clothing:
 - Wear flange cap.
 - Wear dirt/fog-proof glasses.
 - Wear gauze mask.
 - Wear long gloves.
 - Wear coat guarding against poisons.
 - Wear boots.
- Spraying towards personnel and working at the downwind position are prohibited.
- Running the machine without water or lubricating oil is prohibited.
- Using special working solutions as strong acid, strong alkali, etc. is prohibited.
- Following personnel should not use the machine:
 - Mentally challenged.
 - Drunk.
 - Under the age of 18 or older people.
 - Person with no knowledge of the machine.
 - Tired person or patient and others who cannot operate the machine normally.
 - A person who has just exercised strenuously or has not slept enough. Women feeding breast milk to the baby or is pregnant.
- Spraying
 - It is fine to carry out an operation during cool weather with little wind. For example, early in the mornings or in the late afternoons as this can reduce the evaporation and drift of chemicals and improve the protective effect.
 - The operator should move windward.
 - If your mouth or eyes are spattered with chemicals, wash them with clean water and then visit a doctor.



- If the operator has a headache or dizziness, should stop working at once and consult a doctor immediately.
- For the operator's safety, misting/dusting must be carried out strictly according to the instruction of the chemicals and agricultural requirements.
- Spray over, according to pesticide manual to clean out any residual spray mixture in chemical tank.
- After spraying always wash your hands and face thoroughly

OVERVIEW OF COMPONENTS

KK-KPS-204B / 222B

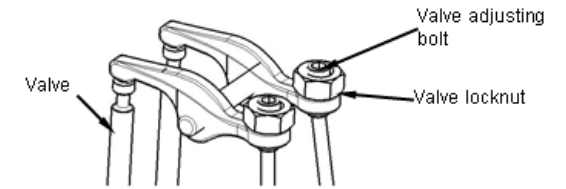
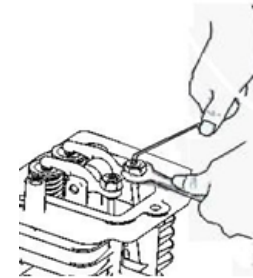
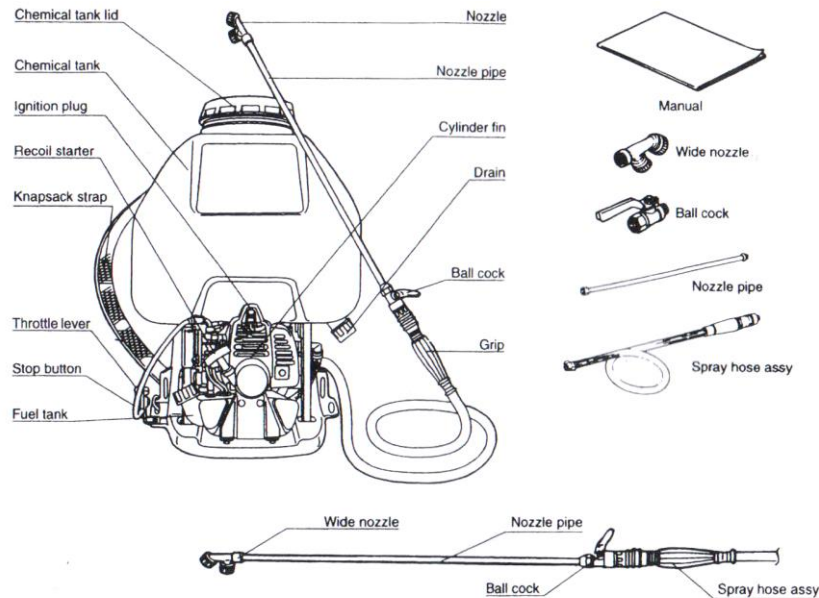

Screw out the bolt to increase the valve clearance.

Maintenance before the Long-Term Shutdown

If the engine will not be used for a long period of time due to some reasons, one time of maintenance of the engine must be carried out before its shutdown:

1. Screw off the fuel tank cap and pour out the fuel in the fuel tank; actuate the carburetor oil pump to discharge the fuel in the carburetor; then, screw up the fuel tank cap.
2. Screw off the oil rule and discharge the lubricating oil in the fuel engine based on operating methods
3. Rotate the crankshaft to stop the piston of the fuel engine at the position of the top dead center, so as to prevent air from getting into the cylinder and rusting the cylinder.
4. Wipe off the oil stain and dust on the external surface with the clean cotton yarn and remove the dirt between the cooling fins, so as to keep the fuel clean. After cleaning, put the fuel engine at a clean, dry and ventilated place for storage.
5. Disposal of waste oil: Please store the waste oil in the fuel engine with a container and deliver it to the local waste oil treatment station for treatment, and do not pour it anywhere.

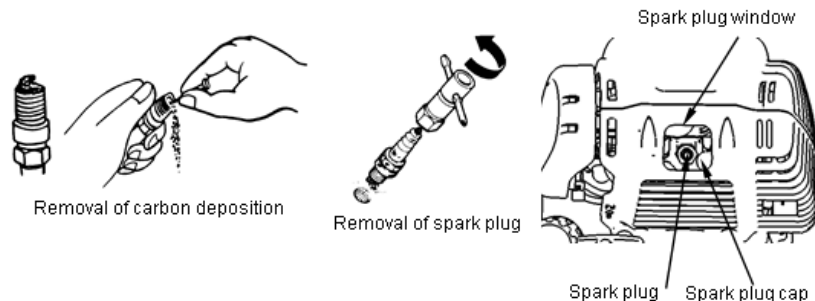

4. Adopt the feeler gauge to measure the clearance of the spark plug. If the adjustment is needed, carry out the adjustment by bending the side electrode.
5. Check whether the washer of the spark plug is in good condition when placing in the spark plug; manually screw it in for 2~3 turns, and then screw it up with the socket special for the spark plug.
6. Reinstall the spark plug cap.

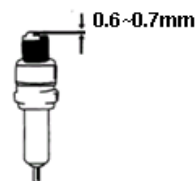

Warning

The spark plug must be screwed up, or it may become extremely hot and damage the fuel engine.

Adjustment of Valve Clearance:

Each set of fuel engines is strictly debugged and inspected by our company. Generally, the engine can get into the normal operation without any adjustment. After it is used for a period of time, you may adjust the fuel engine based on the following steps:

It is suggested to adopt the standard valve clearance: Inlet valve clearance: 0.05~0.08mm; exhaust valve clearance: 0.08~0.10mm.

- a) Hold the valve clearance adjusting bolt and loose the valve locknut.
- b) Turn the valve clearance adjusting bolt to the specified clearance.
- c) Hold the valve clearance adjusting bolt and screw up the valve locknut.
- d) Re-inspect the valve clearance after screwing up the valve locknut.

ASSEMBLY

KK-KPS-204B / 222B

Attach the wide nozzle, the nozzle pipe, the bail cock in an order to the spray hose and connect the other end of the hose to the spray outlet.

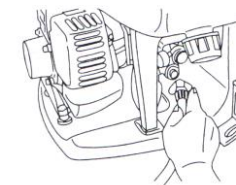

OPERATING INSTRUCTIONS

Pre-Operation Preparation:

Oiling

1. Make sure that the engine is stopped and cooled.
2. Neither overfill nor spill the fuel on the engine

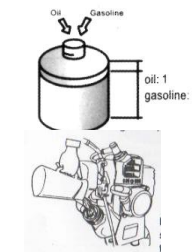

Dilution of chemicals/Charging the chemical tank (Applicable for KK-KPS-204B/222B)

Caution: Agricultural chemicals are extremely dangerous and must be handled with utmost care. Read the manual for the specific chemical carefully before use.

Dissolve water dispersible powder in a separate container before filling, be sure not to get foreign material into chemicals.

Always fill the chemical tank through the strainer so that contaminants are not mixed into the chemicals.

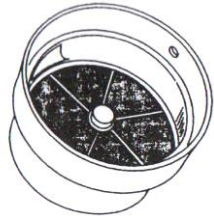

Open the air bleed nozzle, and bleed until the chemical is draining out, and then close the nozzle securely. Before spraying the agrochemical, be sure to put on suitable protective clothing to protect yourself against contact with and breathing it. Observe the following cautions for safe operation:

- Be sure to close the chemical tank cover securely.
- Check the spray hose and nozzle connections to make sure there are no leakage.
- Always stop the engine before refilling the fuel tank or changing the nozzle.
- When carrying a full chemical tank, be careful not to lose your balance.

Starting the Engine (Applicable for both the models):

Important: When starting the engine, be sure to fill the chemical tank with pure water or chemical liquid. Never run the engine when the chemical tank is empty.

- Pump the primer bulb until fuel can be seen flowing through the fuel return line and pull the choke lever to full close. (During hot weather and when the engine is already warmed up, the choke lever may be set to either half open or full open).
- Set the throttle lever to the middle speed position (not necessarily to maximum).

KK-KPS-204B / 222B

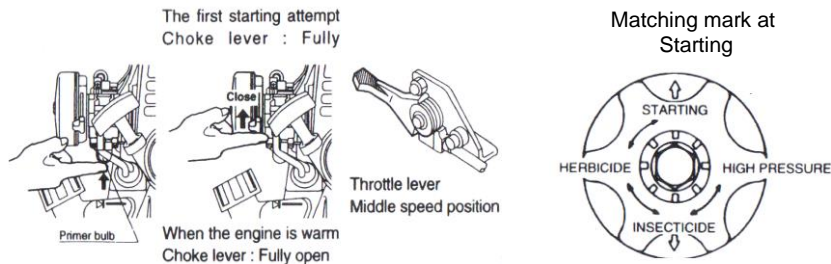

It is strictly prohibited to operate the fuel engine in the case of not installing the filtering element of the air filter as it may accelerate the wear and damage of the fuel engine.

- Screw the bolt of the air filter anticlockwise at the position shown on the figure, so as to take off the air filter cap.

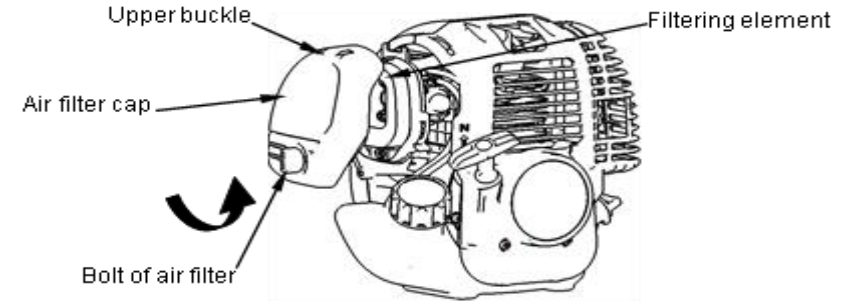

- Use non-flammable solvent or dissolvent with a high ignition point to clean the filtering element and completely dry it.
- Use the filtering element to adsorb the clean lubricating oil for the fuel engine and squeeze out the excessive oil.
- Reinstall the filtering element of air filter.
- Install the air filter cap based on the sequence of firstly mounting the buckle and then screwing up the bolt of the air filter clockwise.

Maintenance of Spark Plug:

To ensure the normal operation of the fuel, the clearance of the spark plug shall be proper and free of deposit.

- Dismount the spark cap in the spark plug window and put it aside.
- Use the socket that is in proper size and special for the spark plug to dismount the spark plug.
- Visually inspect the spark plug, which shall be replaced in case of obvious breakage and damage or crack or defects on the insulator. The excessive carbon deposition shall be also removed.

Item	Maintenance cycle					
	Each time of use	Every 1 month or 10 hours	Every 3 months or 25 hours	Every 6 months or 50 hours	Every 1 year or 100 hours	Every 2 years or 300 hours
Fuel tank	Check				■	
Fuel pipe	Check	Every 2 years (replacement if necessary)				

Note:

- Increase the maintenance interval if it is used in the dusty area.
- The maintenance of these items shall be conducted by maintenance service stations specially authorized by our company, unless the users have appropriate tools and the maintenance ability.
- With respect to those fuel engines for commercial purposes and under long-term operation, their maintenance intervals shall be correctly determined.

Replacement of Lubricating Oil:

It is suggested to release the oil when heating the engine, so as to ensure the quick and complete release of the lubricating oil.

- Check whether the fuel tank cap is screwed up.
- Dismount the oil rule and incline the fuel engine to the neck where the lubricating oil is applied, so as to release the oil to an appropriate container.
- Fill in the recommended lubricating oil and check the oil level.
- Reinstall the oil rule:** In case of lubricating oil overflowing, make sure to wipe off the oil. Wash hands with soap water or detergent after contacting the lubricating oil, and then wash hands with clean water.

⚠ Caution

Please dispose the waste lubricating oil and containers with methods in compliance with environmental protection requirements. It is suggested to store the waste lubricating oil into a sealed container and deliver it to the local waste oil recycle bin for treatment. Do not throw it into the dustbin or pour it on the ground or into the drainage ditch.

Maintenance of Air Filter

The function of the air filter is to filtrate impurities and dust in the air so as to allow the clean air to flow into the combustion chamber for combustion. The dirty air filter will prevent the air from getting into the carburetor. To avoid any fault of the carburetor, it is required to carry out.

⚠ Danger

Do not use fuel or cleaning agent with low ignition point to clean the filtering element of the air filter, or the fire disaster or explosion may occur.

⚠ Caution

Operation (KK-KPS-204B / 222B):

- Turn the handle of the control valve, and set it to the position for HERBICIDE, INSECTICIDE or HIGH PRESSURE to match the pressure of the operating conditions.

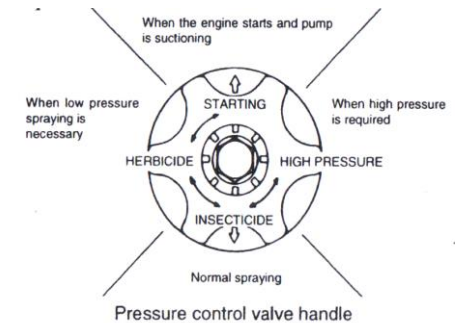

- Check the spraying conditions and the status of the equipment, then shoulder the equipment and set the throttle lever to the high-speed position.

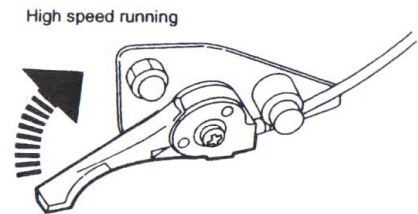

- When the nozzle cock is opened, chemicals will be atomized as they come out of the nozzle.

IMPORTANT

- When the pressure control valve is changed to INSECTICIDE or HERBICIDE, with the throttle being fully open at HIGH PRESSURE position of pressure control valve handle, the engine speed will become too high, corresponding to the extent of lowered pressure. Therefore, use the equipment with the throttle lever somewhat turned back from the fully opened condition when the equipment is used at the position for INSECTICIDE or HERBICIDE.
- Be careful of the amount of fuel in the tank, and refill it when it becomes low.

To Stop:

Temporary halt during operation:

- Close the spray gun and return the throttle lever to low speed.
- Press the engine stop button.
- After the engine stops, set the sprayer down and close the fuel cock.

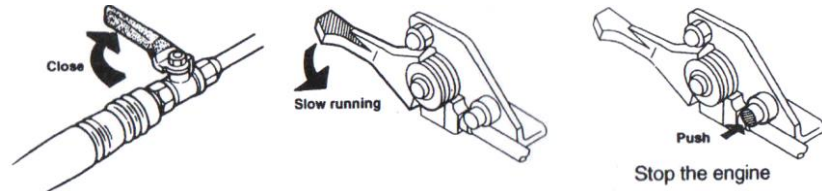

Stopping the sprayer after completing spraying:

1. Remove the chemical tank drain cap, drain off all the chemicals.
2. Fill the chemical tank with clean water, operate the engine, and clean the pump and hose interior by spraying the clean water. Drain off the remaining water through the drain.

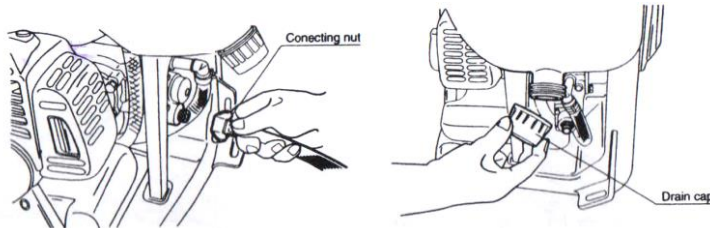

Start the engine at just less than high speed for 15-20 seconds to spray out the water in the spray hose and nozzle. When water stops coming from the nozzle, turn off the engine at once.

MAINTENANCE AND STORAGE

(Applicable for both the models)

Cleaning the air cleaner:

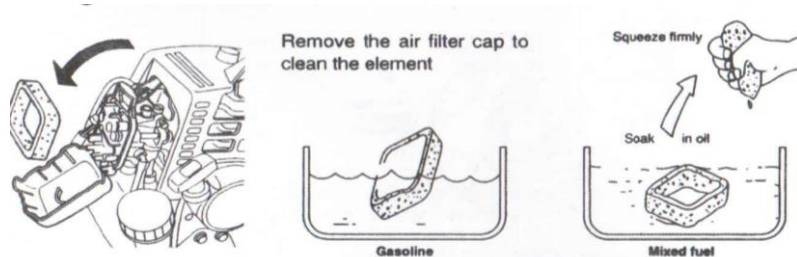

Plug:

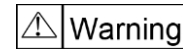

For the sake of your health, please be far away from the muffler and do not directly face the exhaust port during operation of the fuel engine. Pay attention to the unusual change of the fuel during its operation. Immediately shut down the engine in case of abnormal sound, severe vibration, unstable rotating speed, blasting and other adverse phenomena of the fuel engine.

REPAIR AND MAINTENANCE

Maintenance Schedule:

The regular inspection and adjustment must be carried out to ensure the fuel engine maintains its excellent performance. The regular maintenance also ensures a long-term service life. See the following table for regular maintenance cycle.

Item	Maintenance cycle	Each time of use	Every 1 month or 10 hours	Every 3 months or 25 hours	Every 6 months or 50 hours	Every 1 year or 100 hours	Every 2 years or 300 hours	
Lubricating oil	Check the oil level	■						
	Replacement		■		■			
Air filter	Check	■						
	Cleaning			■a				
Spark plug	Check and adjustment					■		
	Replacement						■	
Spark extinguisher (optional)	Cleaning					■		
Cooling fin	Inspection				■			
Bolt, nut and other fasteners	Check (screwing up if necessary)							
Clutch	Inspection				■b			
Idle speed	Check and adjustment					■b		
Valve clearance	Check and adjustment					■b		
Combustion chamber	Cleaning	300 hours later						
Fuel screen	Check					■		

- In case of using the fuel engine in the plateau region, the air and fuel mixture of the carburetor in the normal state will be too dense, which will reduce the running performance of the fuel engine and increase the fuel consumption. Thus, the carburetor shall be replaced with a special one for use in the plateau region.
- With the increase of the elevation, the power of the fuel engine will have some decline.

Operation:

When preheating the fuel engine, gradually move the handle of the choke valve to the "OPEN" position.

Then, adjust the handle of the throttle valve upward and set it at the position of the required running speed of the engine.

Handle of choke valve

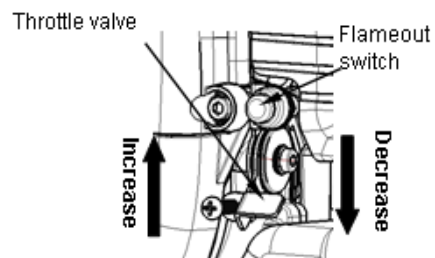
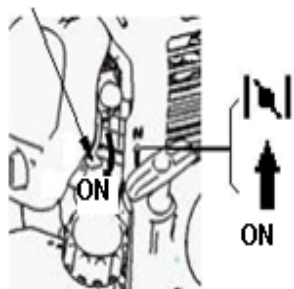

⚠ Caution

To give full play to the product performance, it is suggested to run the fuel engine for about 15 minutes in the low-speed state if the engine is used for the first time. Heat the engine for 3-5 minutes and then get it into the working state every time when it is to be used.

Shutdown

Directly press down the stop switch or pull off the spark plug cap in case of shutdown in an emergency. Generally, conduct the operation based on the following steps:

- Release the load firstly; then press down the handle of the throttle valve to reduce the rotating speed of the fuel engine.
- Press down the stop switch after 2-3 minutes of no-load running.

⚠ Caution

Under normal circumstances, it is strictly prohibited to directly shut the engine down in the case of no load off.

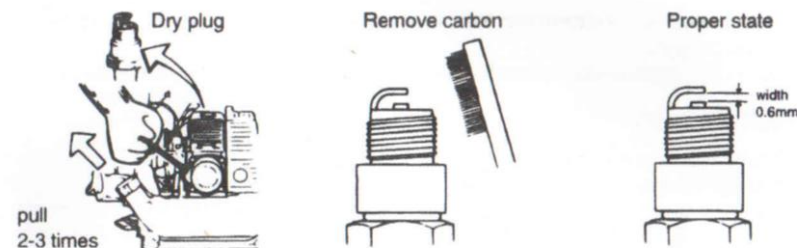

Storage:

After using the sprayer for the season, store it until the next season of use as follows:

- Drain off all fuel from the fuel tank and the carburetor.
- Remove the spark plug and coat the cylinder with a small amount of oil. Pull the recoil starter lightly 2-3 times to spread the oil over the cylinder completely as shown in the figure below.

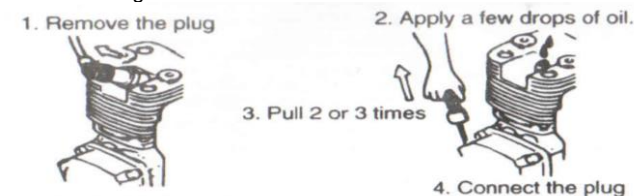

- Pull the recoil starter out slightly and stop it in place where you feel the pull start (compression starts).
- Clean the entire sprayer completely, cover it so it does not accumulate dirt and dust, and store it in a dry, cool location.

TECHNICAL SPECIFICATIONS

Model	KK-KPS-204B	KK-KPS-222
CC	31 cc	35.8 cc
Bore x Stroke	39x26mm	
speed	6500 RPM	
Rated Power	0.7 kW (1 hp)	1 kW (1.3 hp)
Engine Type	4 – stroke	
Comp Ratio	8.3:1	
Max Torque	1.2Nm	
Lube Oil	10W/30SAE	
Fuel Used	Unleaded Petrol	
Fuel Tank Capacity	767 ml	
Liquid Output	7-8 L/min	
Tank Capacity	25 N/A	
Liquid Output	20-25 Liters/Minute	

Note: Specification can be changed without notice.

Startup of Engine

1. Forcibly press the oil pump until the fuel in the fuel pipe (transparent oil pipe) can be seen

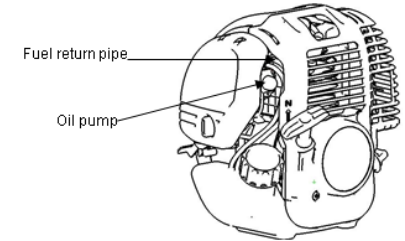

2. Pull the choke valve to the "OFF" position and return

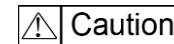

Do not use the choke valve when the fuel engine is hot or in the high-temperature state.

Handle of choke valve

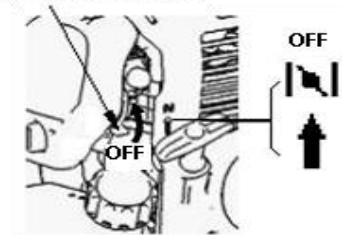

Startup:

3. Grasp the starter handle and slowly pull until you feel the resistance, then firmly pull it outwards.



4. It is required to slowly lay back the handle along the resilience of the starter rope rather than abruptly release the handle and allow it to rebound and strike the fuel engine, which will damage the starter.
5. It is required to quickly pull the starter, or the electrode of the spark plug cannot spark, which will consequently result in the starting failure.

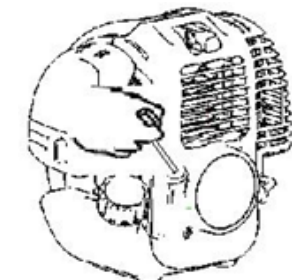

recommended for the fuel engine is -
 5°C~40°C.

Recommended fuel

It is recommended to use unleaded fuel with an octane value of 90# or higher, so as to reduce the carbon deposition in the combustion chamber.

Do not use the out-of-date or polluted fuel or the fuel mixture of engine oil and fuel. It is also required to keep the water or dust from getting into the fuel tank.

Sometimes, there will be spark knock sound or the bang-bang noise in case of overload operation, which is normal.

If the continuous spark knock sound can still be heard when the fuel engine operates under the normal load, it is suggested to replace the fuel with other brands; after then, if the sound still exists, please consult the specially authorized service shop for solution.

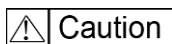

Caution

- Fuel is highly flammable and can explode under some circumstances.
- Refill the fuel in the well-ventilated environment and shut down the engine during refueling; no smoking at the refueling place and no open fire and spark at the fuel storing place is permitted.
- The fuel tank shall not be overfilled (The fuel level shall not be higher than the neck of the oil filler); inspect whether the fuel tank cap is properly covered after the refueling is completed.
- Be careful not to spill fuel when adding the fuel. Spilled fuel or vapor of the overflowing fuel may result in fire. Wipe up any spilled fuel without delay.
- Do not allow children to touch it. Capacity of fuel tank:0.6L

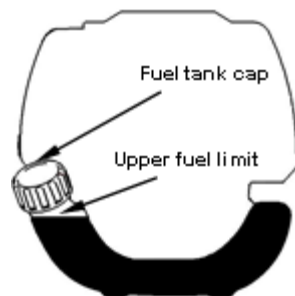
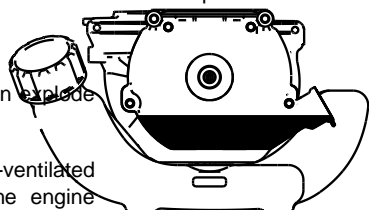

Fuel containing alcohol.

If the fuel containing alcohol (alcoholic fuel) is adopted, the ethanol content in the alcoholic fuel shall not exceed 10%. Do not use alcoholic fuel where the methanol is free of combustion improver and corrosion inhibitor. Though the methanol does contain combustion improver and corrosion inhibitor, the methanol content in the alcoholic fuel shall not exceed 5%.

TROUBLESHOOTING

Pump:

Trouble	Cause	Remedy
No Suction	Hose is Loose	Tighten the hose carefully
	Suction hose is clogged with chemicals.	Disassemble and clean the hose.
	Worn piston packing.	Replace with a new piston
	Foreign object in valve parts.	Disassemble and clean the valve.
Poor spray quality	Worn piston packing	Replace with a new piston
	Flaw in cylinder inner surface	Replace with a new cylinder
	Flaw in exhaust valve	Replace with a new valve
	Worn pressure control valve handle	Replace with a new handle
	Foreign object in valve parts	Replace with a new
	Worn nozzle hole.	Replace with a new nozzle.
	Too many nozzles attached	Reduce number of nozzles or replace with nozzle of smaller holes.

When engine fails to start:

Trouble	Cause	Remedy	
There is fuel, but spark plugs fail to ignite.	There is power at the terminal.	Drawing too much fuel	Tuning the carburetor
		Faulty spark plug gap.	Adjust the spark plug gap
	No power at the terminal	Faulty spark plug insulation.	Replace the spark plug
		Faulty TCI unit or broken wire	Replace the ignition coil.
There is fuel and spark plug ignite	Compression is good	A break or short in the ignition coil.	
		Bad Mixture	Adjust the carburetor
	Compression is bad	Faulty packing	Tighten the spark plug
		Spark plugs not tightened properly	Tighten the spark plug
No fuel in the carburetor		Piston rings are sticking	Replace the piston ring
		No fuel in the tank	Fill the tank with fuel
		Fuel valve is faulty, or fuel tank air vent is plugged.	Clear air vent hole
		Lines are bent	Replace lines

Engine fails to run smooth:

Trouble		Cause	Remedy
No power	Compression is good and there is no misfire	Air cleaner element is plugged up.	Clean or replace air cleaner if necessary
		Air has entered fuel line joints.	Clear the fuel line
		Faulty choke lever	Replace choke lever
		Carbon builds up on cylinder muffler.	Clean the muffler
	Compression is bad	Burnt spark plugs	Replace the spark plug
		Short in cable	Replace the cable
Engine overheated		Bad mixture or piston ring wear.	Replace the piston ring
		Marks on cylinder. Cracks in the piston head	Replace the piston
		Fuel is too low (mixture is too thin).	Engine over oiling.
		Faulty mixture, not enough mixture.	Clear the lines
		Carbon piled up, overloaded operation.	Clean the carbon
Inaccurate explosion		Faulty spark plugs.	Replace the spark plugs
		Plugged cylinder or coolant lines	Clean the coolant lines
		Carburetor not adjusted properly.	Adjust the carburetor gap properly
Engine doesn't sound right		Faulty spark plugs.	Replace the spark plug
		Faulty magneto or internal short	Replace he magnet
		Overheated cylinders	Replace the cylinder
		Overload operation	Right quantities of petrol and oil should be mixed to enable proper lubrication
Slow acceleration		Faulty mixture or incorrect ratio	Replace the necessary spares/contact service person
		Internal engine damage	Adjust the carburetor gap properly
		Carburetor not adjusted properly or faulty compression	Use good quality fuel-oil mixture.
		Poor fuel oil quality	Clean the carbon
		Carbon pile up	

OPERATING INSTRUCTIONS

Preparation and Check Prior to Operation

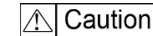

Caution

The fuel engine is not filled with engine oil before it is delivered from the factory. Please fill it with engine oil firstly

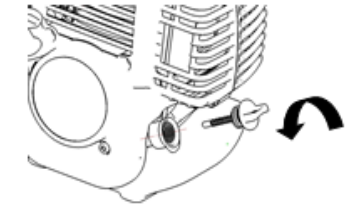

Check the lubricating oil level

1. Shut down the fuel engine and place it at horizontal level.
2. Dismount the engine oil rule and check the oil level, which shall be up to the oil filler.
3. If the oil level is low, fill the recommended lubricating oil to the oil filler
4. Remount the oil rule.

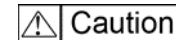
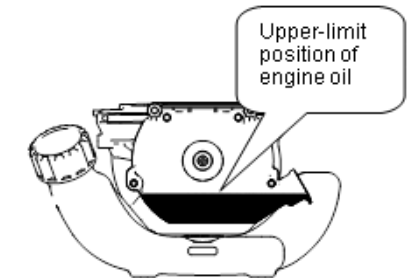

Caution

1. The filling volume of lubricating oil for the fuel engine is 75ml. Due to the small capacity, it is required to slowly fill the oil to avoid overflow or spilling.
2. Check the lubricating oil level of the fuel engine at intervals of 10 hours and fill it up to the oil filler if the fuel engine is required to continuously operate for above 10 hours.
3. Users shall use engine oil of different brands under different ambient temperatures.
4. The use of the lubricating oil free of cleaning agent or the lubricating oil for the two-stroke engine will shorten the service life of the fuel engine. The operating temperature range

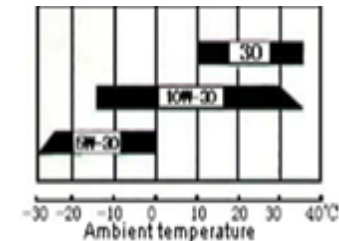



- As the fuel is inflammable and explosive, please make sure to refuel at a ventilated place, shut down the fuel engine before refueling and be far away from cigarettes and spark; the overflowing fuel shall be wiped off immediately.



- Do not use it indoors and make sure to have enough ventilation as the exhausted air contains carbon monoxide.

INSTALLATION

DIMENSION

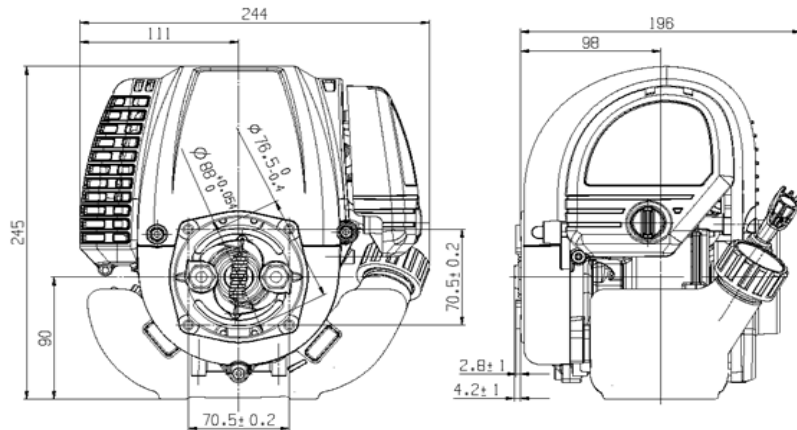

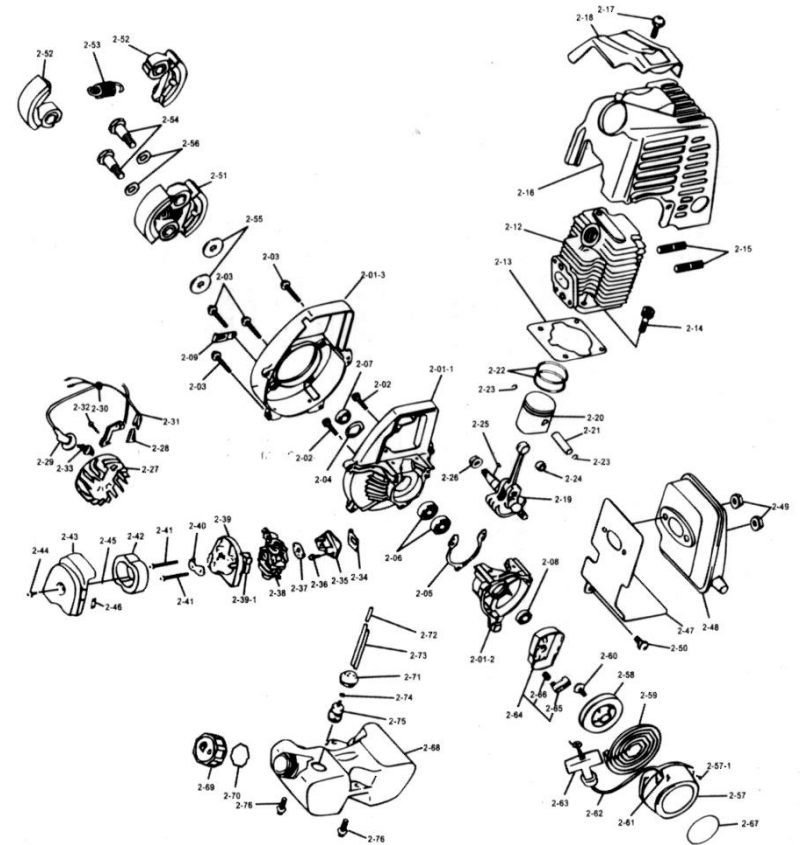

POWER SPRAYER- DIAGRAM-ENGINE

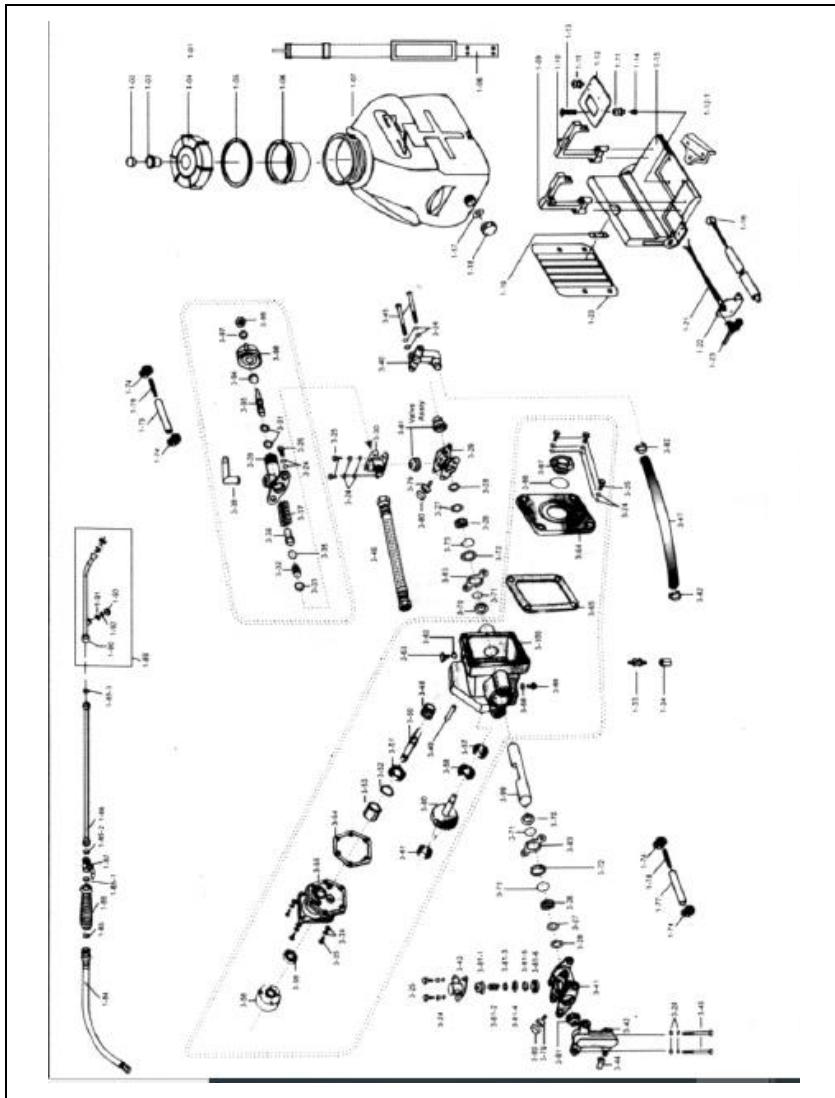

PRESSURE SPRAYER PARTS - DIAGRAM



SAFETY INSTRUCTIONS

1. The fuel engine must be operated by personnel with certain professional knowledge, and independent operation by non-professional personnel is strictly prohibited.
2. Keep the fuel beyond the reach of children.
3. It is not allowed to place inflammable, explosive, and other dangerous articles around the fuel, so as to avoid the fire hazard.
4. The workplace shall be of smooth ventilation and be above 10m away from the combustion source.
5. The engine must be shut down when adding fuel or lubricating oil.
6. Smoking is strictly prohibited in the course of refueling, and overflowing of fuel is not allowed; if it overflows due to carelessness, the oil stain must be completely cleaned prior to the startup of the fuel engine.
7. To prevent your fuel engine from being damaged, please do not start up the engine when the lubricating oil is not applied or when the applied lubricating oil is insufficient.
8. Do not operate the fuel engine when you are not quite sure or under the influence of alcohol. Otherwise injury may result.
9.  **Caution** Prolonged or repeated exposure to fuel or engine oil may cause skin carcinoma, even though this possibility is very low. Wash hand thoroughly with soap and water after handling fuel and engine oil.
10.  **Caution** We recommend that the users place the used fuel engine oil into closed containers and deliver containers to the waste treatment yard or reclamation depots.
11. Don't allow used fuel and engine oil to spill on ground or be drained into wastewater piping or sewers.
12. Keep the fuel engine hot and in horizontal position to drain engine oil rapidly and completely.
13. For the sake of the safety of your own and the others, please pay special attention to the following safety signs.



- If it is operated based on the operating manual, this fuel engine can provide safe and reliable operation as designed. Please carefully read and understand this instruction manual before operating the engine, or it may cause personal injury or equipment damage.



- Do not touch the muffler during operation and shutdown of the fuel engine as it is very hot. Place the fuel engine in a room after it cools down.
- As the exhaust system of the fuel engine is very hot during its operation and at the time of shutdown. Please pay attention to the warning label on the fuel engine to avoid being burnt.

GENERAL DESCRIPTION

The normal operation of the engine can be guaranteed under the natural environment of 268–313K. This type of fuel engine can be used as the power source for the fuel engine driven water pump, gardening equipment, lawn mower and other general machinery.

This instruction manual is not applicable to fuel engines for special purposes such as fuel engines for motorcycle and outboard engine.

This general fuel engine series is of excellent quality. They can be started up easily and reliably with strong power output, remarkable oil-saving effect, low operating noise and emission. There are diversified types of power take-off ends, and our perfect after-sales service system ensures that you will have a most trouble-free and satisfying fuel engine.

This series of fuel engines are of single-cylinder, four-stroke, small, light in weight and compact in structure, and adopt the forced air cooling, overhead valve, inductive ignition and recoil-type hand-operated startup.

This manual contains the latest information on operation and maintenance of the engine (the illustration in the manual is indicative and only for reference). As our products are constantly in the process of further improvement and development, they are subject to improvement or alteration without notice.

In case the fuel engine is resold, this instruction manual shall be regarded as an integral part of the fuel engine and delivered with it.

Warning Please read this manual thoroughly before operating the engine and observe these instructions contained in this manual strictly. Our company's safe and reliable fuel engines can operate safely and reliably and not result in personal injury or equipment damage. Failure to comply with these instructions will result in serious injury or equipment damage.

STRUCTURAL DIAGRAM

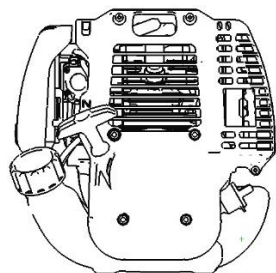

WORKING PRINCIPLE:

The fuel is burned in a single cylinder to drive the piston for reciprocating motion, by which the chemical energy of the fuel is converted into mechanical energy; sequentially, the power output is realized.

PRESSURE PUMP PARTS-LIST

No.	Parts name	No.	Parts name
1.	Tank lid assy. (02-05)	3-32	Valve seat
1.	Sieve	1-33	Shake-proof plug 6mm
1-03	Cowl	1-34	Pump bracket
1-04	Tank lid	3-35	Ball valve
1-05	Seal	3-36	Spring seat
1-06	Sieve filling	3.	Spring
1-07	Water tank	3-38	Overflow joint
1-08	Carrying strap assy.	3-39	Pressure regulating valve body
1-09	Right bracket	3-40	Right suction chamber
1-10	Left bracket	3-41	Left pressure chamber
1.	Shake-proof plug 6mm	3-42	Left suction chamber
1-12	Engine seat	3-43	Left delivery chamber
1-12-1	Fixing bracket	3-44	Suction joint
1-13	Screw Assy. Mfix15	3-45	Hex bolt Mhx73
1-14	Nut	3-46	Pump delivery. hose assy.
1-15	Chair	3-47	Pump suction hose
1.	Way	3-48	Roller bearing
1-17	Washer	3.	Pin
1-18	Drain cap	3-50	Pinion shaft
1.	Coupling metal	3-51	Ball bearing 6201
1-20	Pad	3-52	O-ring I 2x1.8
1.	Stop switch	3-53	Bush
1.	Lever seat	3-54	Gasket, upper case
1-23	Lever	3-55	Upper case
3.	Washer	4.	Clutch drum
3.	Hex bolt M6 xl6	4.	Ball bearing 6200
3.	Grease ring	3-58	Ball bearing 6203
3.	V-packing	4.	Oil seal for upper case
3-28	Adjusting ring	3.60	Gear shaft
3-29	Right pressure chamber	4.	Ball bearing 608
3-30	Right delivery chamber	3-62	O-ring I 2x1.8
3.	O-ring 10x1.8	3-63	Oil inlet bolt

No.	Parts name	No.	Parts name
4.	Gear box cover	2.	Ball cock
3-65	0-ring, gear box cover	2.	Spray rod
3-66	0-ring,oil window 3lx3	2.	Fan nozzle assy.
4.	Oil window	1-90	Nozzle body
3-68	0-ring 6.3x1.8	2.	Filter bowl
3-69	Oil outlet bolt	1-92	Spraying plate
3.70	Oil seal for piston	1-93	Spraying lid
3-71	0-ring for piston 1%1.8	3-94	Cap nut
3-72 .	Packing seat	3-95	Regulating screw
4.	0-ring 18x2.65	3-96	Adjusting pan
1-74	Hose clamp	3-97	Washer
1-75	Overflow hose	4.	Nut
1-76	Overflow spring	3-99	Piston
1-77	Suction hose	3-100	Gear box body
1-78	Suction spring		
3-79	Grease cup		
3-80	Cap for grease cup		
4.	Valve assembly		
3-81-1	Valve cage		
3.81-2	Valve spring		
3-81-3	Valve plug		
3-81-4	Valve seat		
3-81-5	Valve ring		
3.81-6	Valve packing		
4.	Hose clamp		
4.	Metal plate washer		
1-84	Spray hose assy.		
2.	Washer		
1.85-1	Washer		
1-85-2	Washer		
1-85.3	Washer		
2.	Handle		

USER MANUAL-4 STROKE PETROL ENGINE

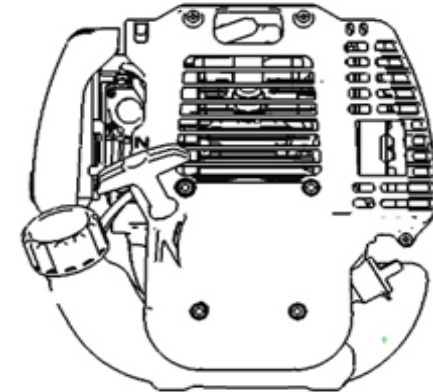

BEFORE GETTING STARTED

Please read this manual thoroughly before operating this fuel engine. The manufacturer reserves the right to modify this manual without notice. The manufacturer shall assume no liability for incorrect information contained in this manual. Copying of any contents of this manual are forbidden without written approval. Some important information in this manual will be indicated in the following way. The users should pay special attention to these instructions.

⚠ Danger This indicates a hazardous situation, which, if not avoided, will result in death or serious injury.

⚠ Warning This indicates a hazardous situation, which, if not avoided, could result in death or serious injury.

⚠ Caution This indicates a hazardous situation, which, if not avoided, could result in minor or moderate injury.